

CHINT | **EGEMAC**

NGC8 Low-voltage Switchgear





Frankfurt(Oder)



Hangzhou



Shanghai



Wenzhou

Constant Brand Concept

- CHINT is the leading brand in the domestic industrial electrical field.
- The operation concept of CHINT is to "Create Values for Client, Seek Development for Staff and Shoulder Responsibility for Society".
- The constant brand spirit of CHINT is "Empower the World".
- CHINT involves new energy, PTD equipment, low-voltage apparatus, instrument, industrial automation, building electric, automotive electrical appliance and etc.



Renewable Energies



Transmission and Distribution Equipment



Low-Voltage Electrical Appliances



Instrument and Meter



Automation



Building Electrical Appliances



EGEMAC (The Egyptian German Electrical Manufacturing Co) was established in compliance with the law No.43 of the year 1974 and the joint investment law no.230 of the year 1989.

- The real production activities have started since January 1979 in technical cooperation with the best international manufacturer of switchboards at that time (SIEMENS AG GERMANY).
- Since that time, **EGEMAC** is still being pioneer in manufacturing Switchboards and control panels for the Egyptian Electricity transmission and distribution networks of different voltage levels from 400 V up to 500 KV.
- The share of **EGEMAC** in the local market is more than 60% of the best quality with the most advanced technology of our products.
- **EGEMAC** has a technical cooperation with the most international producers like Schneider, Alstom, PFIFFNER, SIEMENS, **Chint**, Elko.
- **EGEMAC** has different ISO certificates (ISO 9001, 14001 and 18001).
- The total area of **EGEMAC** Company is 76,000 square meters with 700 employees.
- **EGEMAC** started with a Capital of EGP 5.5 Millions increased in 2004 to EGP 250 Millions.

Founders :

- 62.48 % The Egyptian Electricity Holding Company (EEHC).
- 24.96 % The National Company for Construction and Reconstruction.
- 5.09 % Misr Company for Mechanical and Electrical Projects (KAHROMICA).
- 4.58 % El-Nasr Transformers & Electrical Products Co (ELMACO).
- 2.89 % Siemens Company. (Munich and Berlin, Germany).

EGEMAC contributes in the capital of other electrical and industrial companies with the following shares :

- 79 % of El-Nasr Transformers & Electrical Products Co. (ELMACO).
- 49 % of XD-EGEMAC High Voltage Electric Equipment Co.
- 10 % of The African for Mechanical and Electrical Projects in Libya .
- 8.17 % of the Egyptian Company for Manufacturing Electrical Insulators (ECMEI).
- 5 % of Design and Manufacturing Co. for Investment equipment (DAMCO).
- 49 % of **Chint-EGEMAC Low Voltage Electric Equipment Co.**

CHINT - the Leading Brand of the Whole Industry Chain in Industrial Electric in Asia

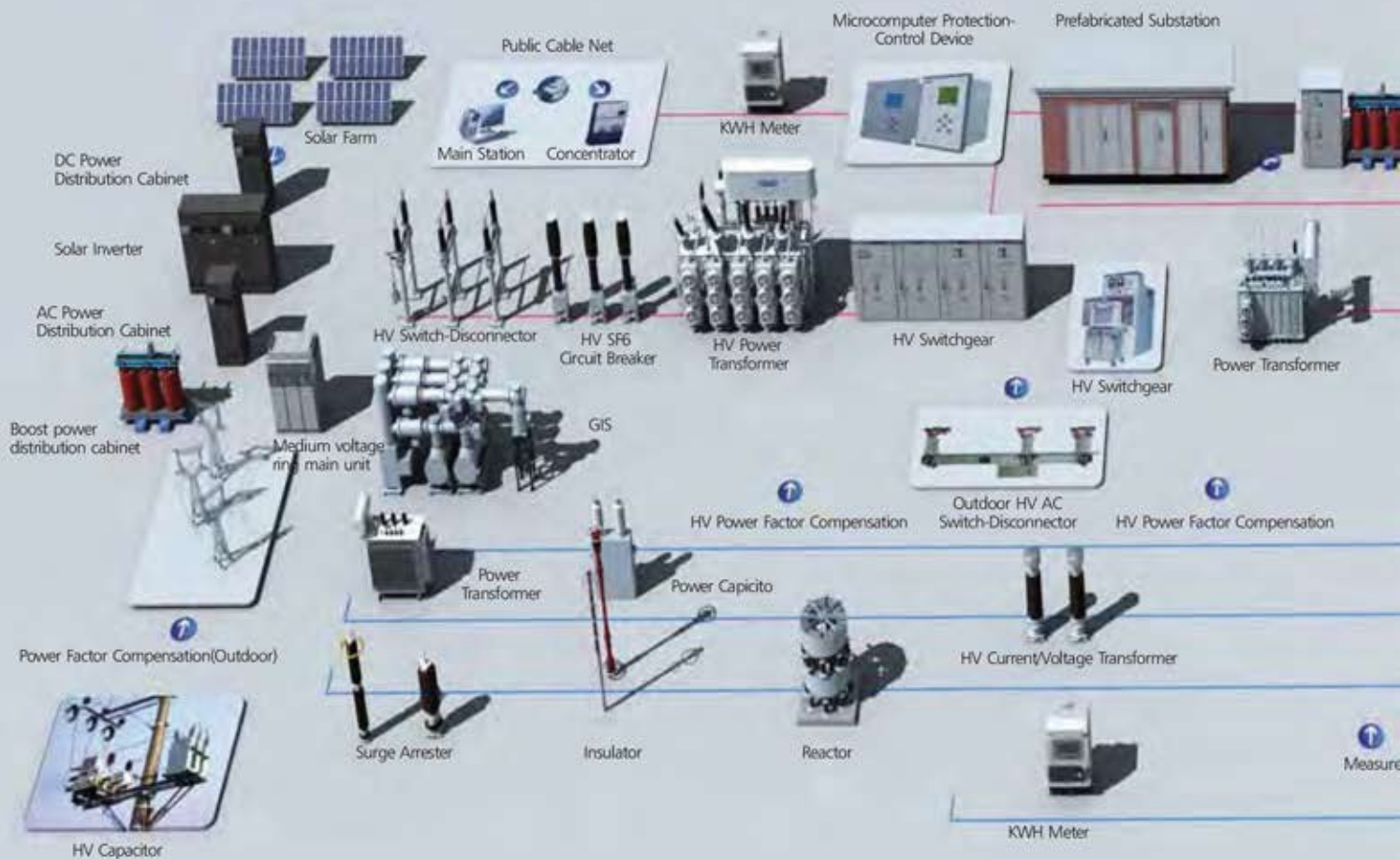

Founded in 1984, CHINT GROUP has been providing the world with safe, reliable and stable industrial electrical equipments and solutions for energy efficiency management system; After 30 years' development, it has been grown from Asia's largest low-voltage electrical products supplier into the leading brand of the whole industry chain in industrial electric in Asia. CHINT's sales revenue has exceeded 5 billion Euros in the year of 2014. With 3 R&D centers located in Europe, US and China, branches in over 20 countries and more than 30000 employees over the whole world, CHINT has provided reliable products, system solutions and services for more than 100 countries worldwide.

CHINT's sub-brands include CHINT, NOARK, ASTRONERGY, XINHUA, CHITIC and others, covering photovoltaic power generation, industrial automation, power transmission and distribution equipment, low voltage electrical apparatus, instruments and meters, building electrical appliance, automotive electrics and other fields. Forming the leading superiority in the whole industry chain in electric from the generation, transmission, substation, distribution of electrical power to the terminal uses, CHINT is providing systems support from products to solutions services to customers worldwide.



CHINT - Empower the World

R&D, QUALITY, SALES, LOGISTICS

Great Quality

By providing reliable products and service for clients, CHINT puts forward the concept "Great Quality." Quality control and upgrade is divided into four systems: scientific research, quality control, marketing service and logistics distribution. These methods and strategies make a comprehensive upgrade to product quality and services. Emphasis on "prevention first, continuous improvement" is the basis of an effective quality inspection system. Leading the management process of "Great Quality" in the production process controls each link of production accurately and realizes the institutional operation of quality improvement.

"Great Quality" is not just a slogan, but a belief rooted in each employee's work. High-quality and accuracy are the basic requirement. Starting from a routine operation by each staff to implementing a high-quality of production and service, CHINT is your most reliable partner.

Service Concept

Sincerely care for customers, quality creates value

Service Purpose

Innovative and progressive, satisfying the customers



Integrated Vertical R&D

By gathering the global industry elites to Provide safe and stable energy-saving green and advanced electric products.

5%

At least 5% of revenue is invested in research and development

Great Quality System

Ensuring flaw-free and trouble-free products, the multi-dimensional and multilevel control is conducted through procurement, inspection, quality control and certification.

One-stop Services

CHINT's concept is that it is not difficult to fulfill a high-quality logistics distribution at one time, while it is difficult to stay as accurate and prompt as the first-time. High-efficiency and high-precision accuracy are our requirement.

48-Hour Response

Providing end-to-end one-stop services for customers with complaints, business consulting and technical support by solving problems immediately and including any possible problems in advance.





Qualifications

Our products are certificated through: UL, CE, TUV, EAC, KEMA, RCM and RCC.



Low-voltage Switchgear	
<p>NGC Switch Cabinet Overview</p> <ul style="list-style-type: none"> • Development of Switch Cabinet • Features and Application • Typical Arrangement • Technical Data 	Page 01
<p>Security, Effectiveness and Economic Efficiency at Runtime</p>	Page 03
<p>Functional unit of drawer</p>	Page 05
<p>Bus System</p>	Page 06
<p>Feature Composition and Structure</p>	Page 07
<p>Key Component Design</p>	Page 07
<p>The Best Temperature Controlling(Ventilation and Cooling)</p>	Page 08
<p>Intelligent Control System</p>	Page 08
<p>Typical Primary Circuit Program</p>	Page 09
<p>Internal Partition Form</p>	Page 22
<p>Defense Level</p>	Page 23
<p>Installation and Transportation</p>	Page 24
<p>Ordering Instruction</p>	Page 25



NGC8-LV Switchgear

1. Switch cabinet overview

1.1 Development of switchgear

CHINT is a world leading manufacturer of low voltage cabinet and low-voltage components.

Since the development of switchgear product series NGC began in 1995, CHINT has continued to invest heavily in innovative & D. Therefore, as the latest product development--its third generation NGC8 switchgear and every generation of its products could compete with the renowned manufacturers worldwide on the same stage, including ABB, Schneider, etc..

NGC8 series switchgear is widely used in engineering projects, whose technology level is nothing less than ABB's MNS 3.0, Siemens' 8PT, Schneider's OKKEN. However, with Chint's reliable independently-produced low-voltage components, low-voltage distribution switchgear and control system of NGC8 switchgear has excellent cost control, and with the optimal allocation by Chint's professional engineers, it can help lower costs dramatically!



1.2 Features and applications

CHINT-EGEMAC Electrical Equipment Co., Ltd. is the only NGC8 low-voltage switch cabinet production base of CHINT Group in Egypt, who imported many advanced production lines with management level from China CHINT.

NGC8 system, as a fully-tested type (abbreviated as TTA) combination of low-voltage switch cabinet, is accordance with IEC 61439-2 standard. The uniform application modular principle of electrical and mechanical design all selects and uses standard elements and components, whose convenient and flexible compact design has a corresponding according to the operating and environmental conditions.

NGC8 has the following significant advantages in the design:

- Full range cover of functional cabinet
- compact construction, space-saving cabinet
- Back to back installation program
- Excellent equipment configuration with economic efficiency
- Special design and special materials with excellent arc protection capability
- Earthquake resistance, anti-vibration and shock design
- Maintenance free busbar and frame construction
- Best protection for personnel and equipment
- High equipment reliability and operational continuity
- Complete TTA test

NGC8 can be applied to the following industrial environments

- Oil & Gas
- Chemical / petrochemical
- Power Station
- Papermaking Industry
- Water Treatment
- Mining Industry
- Steel Industry
- Food Industry
- Ship Industry

The following are the municipal infrastructure:

- Data Center
- Airport
- Office Building
- Shopping Mall
- Hospital
- Railways

1.3 Technical data

Standard	Switchgear that passed TTA			
Test report	Egyptian National electric lab certification			
	KEMA lab certification			
Electric parameter	Rated voltage	Rated insulation voltage	690V/1000V AC, 3P	
		Rated working voltage	400V/690V AC, 3P	
		Rated impulse voltage (Uimp)	6/8/12kV	
		Overvoltage degree	II/III/IV	
		Pollution degree	3	
	Rated frequency	to 60HZ		
	Rated current	Main busbar	Rated current (Ie)	to 6300A
			Rated peak withstand current (Ipk)	230kA
			Rated short time withstand current	100kA
		Distribution Bus	Rated current (Ie)	to 2000A
Ie Rated current			to 143kA	
Rated short time withstand current	to 85kA			
Structure feature	Size	Cabinet and supporting components		
		Recommended height	2200mm, 2400mm	
		Recommended width	400mm, 600mm, 800mm, 1000mm, 1200mm	
		Recommended depth	600mm, 800mm, 1000mm, 1200mm	
	Surface protection	Modular	E = 25mm	
		Framework	Al-Zn-plated	
		The internal chamber clapboard and component mounting plate	Al-Zn-plated	
		Beam installation	Zn-galvanized	
	Protection grade, plastic parts	Case	RAL7035 Electric paint bright grey	
		According to IEC529	To IP54	
No halogen, self-extinguish		DIN VDE 0304		
No CFC, inflaming retarding		IEC 707		
The internal chamber partition	To Form 4			
Customized according to customer request	Bus system	bus	Heat-shrinkable tubing, silver-galvanized, Sn-galvanized	
	Special aptitude	Test report	KEMA Test report	
	Spraying paint	Case	Customized according to customer request	

1.4 Typical arrangement

The security and effectiveness at runtime

NGC 8 system is a modular type-tested low-voltage switchgear (abbreviated as TTA)

It meets IEC 61439-2 standards, installation and connection of the system is performed according to the standard IEC364



Monitor Incoming Feeder MDB MCC(Fixed) MCC(Drawer) MCC(Drawer) MCC(Plug-in)



The Security and effectiveness at runtime

NGC 8 system is a modular type-tested low-voltage switch cabinet (abbreviated as TTA)

It meets IEC 61439-2 standards, installation and connection of the system is performed according to the standard IEC364



Finland Helsinki Metro
CHINT's Products



URALCRANE Company
CHINT's Products

Working and environmental conditions

NGC8 low-voltage switch cabinet and electrical equipment is installed for indoor switch cabinet, and when it is under other operating conditions, the protection level is up to IP54.



Ukraine Dnieper River Hydropower Station



Iray Salah-Aldeen 2X630MW Power Plant

Ambient temperature requirements

Short-term maximum temperature + 40 °C

When the device is running higher than the above-sated temperature, run with derating capacity according to the actual situation. For the measurement, the measuring instruments and protective relays and other working conditions, it should follow the manufacturer's regulations

Environmental conditions

When it is in normal working condition, the environmental condition should be in accordance with IEC 61439-2 . Ambient relative humidity should be 50% at 45 °C .

Conditions within the indoor switch cabinet installation should meet the relevant standards. If it is in a condition where there is condensation, the switch cabinet will adopt measures such as ventilation or heating to prevent condensation.

If the switch cabinet is installed above an altitude of 2000 meters, then the device should run with the appropriate derating capacity

Business partner



2. Cabinet unit

Cabinet drawer is composed by drawer unit compartment, appeared terminal compartment, cable compartment and lateral horizontal bus compartment, all of whose components are mounted in the drawer unit. There are drawer specifications as follows: 6E / 4, 6E / 2, 8E / 2, 4E, 6E, 8E, 12E, 16E, 20E, 24E (E=25) and other 10 kinds of specifications. The maximum current can be up to 630A.

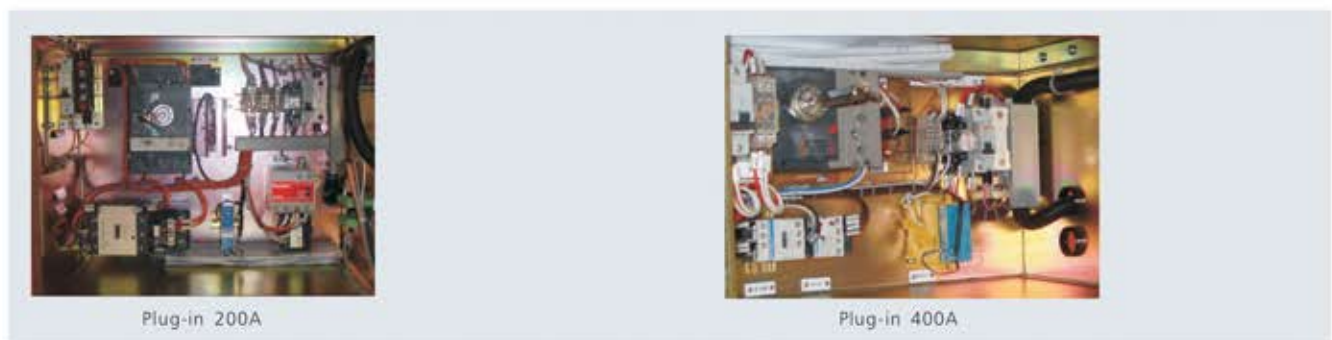

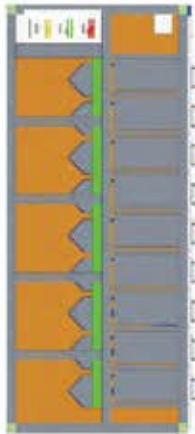

Structure

3. Cabinet structure

Flexible design, compact surface

Shelves

Cabinet frames are made of some special D type of material (modulo as 25mm), which employs the special aluminum connection by locking self-tapping screws and the bolts with high strength to fasten and assemble. There are many a variety of specifications. This type of material can compose cabinets with different specifications and different usages according to the actual need and corresponding modulo.

- The Materials of cabinets employ the 2.0 type of aluminum coated zinc plate and 2.0 type of galvanized steel, to produce framework, flexible processing technology is used to ensure the accuracy and strength with good grounding continuity.
- The chosen design and materials can maximize the prevention of arc fault from occurring and in the event of an arc, it can be extinguished in a short time.
- The selected plastic materials are free of CFC and halogen, and flame retardant and self-extinguishing, therefore, it does not pollute the environment and endanger personal safety.

Door panels and roof

- Door panels: using one or multi-sector in front of the switch cabinet to close according to actual needs. All the doors can choose the left hand model or right hand model. It should be ensured that the spring locks will lock the doors, at the same time, it can balance pressure generated from the gas.
- Top and bottom plates: outlet of top and bottom plates can be designed according to the actual protection degree

Back plate and lateral plate

- When leaning against the wall, back plate can choose blanking plate, and it can switch to openable door after qualifying, while the lateral plate can be made of the steel plate bending, and it should keep the same style with the door panel after assembly.



Shell

4. Busbar system

Horizontal Bus

- The horizontal bus of the switch cabinet should be arranged at the horizontal bus compartment. When installed against a wall or back to back installation, the horizontal bus is placed behind the cabinet, while the horizontal bus should be placed on top of the cabinet after qualifying.
- The bus materials are T2 copper, whose specifications are: 30×10, 40×10, 60×10, 120×10 etc. bus lap can use the new technology, different specifications of copper can be connected at will, and all the bolts can use 8.8 fasteners.
- The maximum current bus level can be up to 6300A, short-time withstand current can be up to 100KA.

Vertical Bus

- Optional vertical bus can select "L" shaped copper, or copper filling can also be used, or to combine two kinds of copper.
- Vertical row can select "L" shaped copper, and the matched insulating component is function plate, who is good in safety performance, small in size, the maximum current can reach 1000A.
- Vertical row can select rectangle copper, the matched insulating member is bus folder, whose security is high and performance is good, high volume, the maximum current can reach 2000A.
- Vertical row can select "L" shaped copper to compose with rectangular copper, and the supporting insulator is functional board with insulating housing, who is good in safety and performance. The maximum current can reach 1500A.

The protection level of cabinet units can reach IP20 after withdrawing.

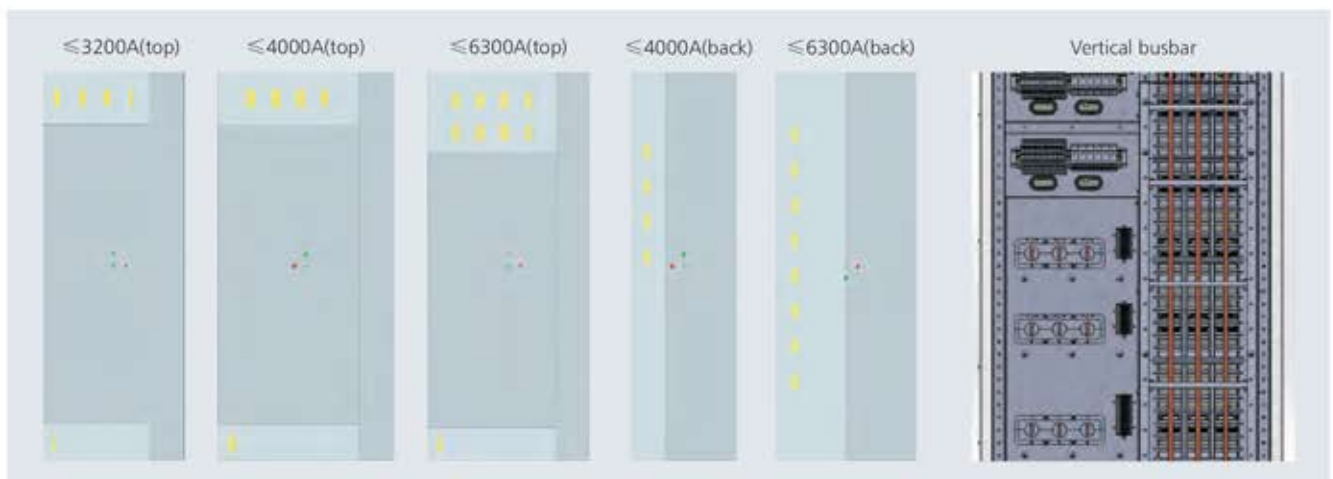



Functional unit



Cable chamber



Adapt



plug-in for primary



Three location device



Three location propelling device above 400A

5. Control of small bus

- Control small bus can provide power to the entire control loops, as well as some of the power supply of communication equipment or field bus.
- Control small bus can be installed in a dedicated compartment, and it can be laid throughout the system as needed.

Protective conductor

- Protective conductor can be used to ensure the equipotential connection of framework, which sits at horizontal and vertical conductors of every cabinet, and all the protective conductor is connected to the framework, vertical conductor can be used for connection of power cable protective conductor and ground wire .
- Cross section of protective conductor can select the corresponding standard to produce the standard copper bus according to the actual current

6. Functional components and structures

Bus room (horizontal and vertical)

- Horizontal bus is located at the top of the bus chamber(back of outlet)and the rear middle (front outlet)

- Vertical bus is located inside the insulating multifunction device unit cell

- Device small chamber is located in front of the cabinet unit, with each chamber only installed with a main element component. A cabinet can at least be installed with one functional element and 36 small functional elements the most.

- The smallest single chamber can be done 4E (100 high)

Cable chamber

- The dedicated channel for laying the power and control cables is located in a separate compartment in the front or rear of the cabinet

- Install the cable inlet or outlet flange at the bottom plate or cover plate according to the actual size of the cabinet and the inlet and outlet methods.

- Extend or compress the cable compartment size according to user needs with appropriate modulus

- cable compartment can be done in different forms of partition according to the internal form

7. Key component design

Profiles

- The profiles overcome the existing strength weaknesses of type C profile, with the use of rebar binding and seamless welding processing, which not only improves the strength but also increase the advantages of maintained C profiles. Our company has applied for a patent for the profile.

Switching unit

A primary outlet adapter: take full consideration of personal safety. The internal partition form can be up to form 4b, while the outlet employs the fully-enclosed form, and the side outlet employs insulation cover (Bellows).

Power-saving three-position mechanism

- The company developed the NCG-6 series chain advancing mechanism, which can be easily and flexibly, steadily removed out of the drawer. The three-position has the evident functions of mechanical lock, display and voice prompts.
- Mechanical three-position is synchronized with electrical three-position lightweight drawer three-position mechanism. Three-position auxiliary contact configuration test position power.
- The interlock mechanism is developed and designed by our company and we have applied for a patent that is key protected by our company.

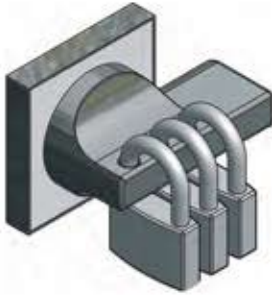

8.The handle

The handle epitomizes our company's own research and development strengths and innovation, which absorbs the strong points widely and it is the product of absorption and innovation, and it can achieve all the relevant requirements, and it has been applied for the new patent.

Drawer design

- Every drawer unit has plastic guides for accurate insertion and withdrawal. There is anti-fall device an all guide to prevent accidental drawer slide.
- The instrument panel on the drawer panel is door opened for ease wiring and easy instrument installation.
- The selected insulating materials are free of CFC and halogens, with spontaneous combustion and self-extinguishing, which does not pollute the environment and endanger personal safety
- Loop interchangeability is excellent, so the units with the same specifications are interchangeable.

9.Ventilation and cooling

- Natural circulation cooling system that uses upper and lower ventilation board, in which the internal metal partition takes full account of ventilation heat requirements.
- The top of cabinet with high amount of heat such as capacitor cabinet employs special design, which can maximize the ventilation.
- Under the case of high current (main bus 4000A or more), the magnetic separator and partition should be used to effectively prevent eddy current heating.
- Bus uses heat-shrinkable tubing, which improves the safety performance and is conducive to heat.
- High-quality plug-ins and branch bus connector provides good performance and reduce heat patch point.
- Equipment with high degree of protection will be deratingly designed and manufactured for heat dissipation.

10.Intelligent control system

NJZ3.0D energy management control system uses computer technology, network communication technology, embedded hardware and software technology, through the master control center and monitoring sub-stations and by dint of network (such as Ethernet, data communication networks, telephone networks, fieldbus networks, etc.) to connect to access to all on-site intelligent installation IED (smart electrical secondary equipment such as: various protective location, device, location, device monitoring and control, reactive power compensation, power meter, special equipment controller, etc.), which enables the remote monitoring of on-site electric primary equipment (transformers, bus, switch, CT / PT, feeder line/cable, capacitor, electric motor ,UPS, owned units, etc.). The system will provide large power users with safe and reliable and economical supply of electrical energy, which provides a solid technical security that greatly improves the efficiency and management of the daily operation and maintenance of the electricity supply

Cabinet intelligent monitoring device



11. Typical primary circuit program

Draw-out type 380VC 50HZ system

No. for Primary Circuit		01						02						
		A	B	C	D	E	F	A	B	C	D	E	F	
NGC8 LV switchgear														
Usage		Electricity supported						Electricity supported						
Rated current (A)		6300	3150	2500	2000	1600	1250	6300	3150	2500	2000	1600	1250	
Main circuit electrical appliance	Disconnector	EX9A	6300	3200	2500	2000	1600	1250	6300	3200	2500	2000	1600	1250
		NA8	6300	3200	2500	2000	1600	1250	6300	3200	2500	2000	1600	1250
		NA1	6300	3200	2500	2000	1600	1250	6300	3200	2500	2000	1600	1250
Current induction machine	BH-0.66- α /5	3	3	3	3	3	3	3	3	3	3	3	3	
Unit high modular ratio		9						9						
Cabinet width(mm)		1000		800		800(600)		1000		800		800(600)		
Cabinet depth(mm)		1000(800)			1000(800)			1000(800)			1000(600)			
Remark														



Draw-out type 380VC 50HZ system

No. for Primary Circuit		03						04				05					
		A	B	C	D	E	F	A	B	C	D	A	B	C	D	E	
NGC8 LV switchgear																	
		Usage		Electricity supported				Bus tie				Double power supply					
Rated current (A)		6300	3150	2500	2000	1600	1250	3150	2000	1600	1250	2000	1600	1250	1000	800	
Main circuit electrical appliance	Disconnecter	EX9A	6300	3200	2500	2000	1600	1250	3200	2000	1600	1250	2000	1600	1250	1000	800
		NA8	6300	3200	2500	2000	1600	1250	3200	2000	1600	1250	2000	1600	1250	1000	800
		NA1	6300	3200	2500	2000	1600	1250	3200	2000	1600	1250	2000	1600	1250	1000	800
Current induction machine	BH-0.66-□ /5	3	3	3	3	3	3	3	3	3	3	3	3	3	3	3	
Unit high modular ratio		9						9				9					
Cabinet width(mm)		1000		800		600		1000		800		1000					
Cabinet depth(mm)		1000			1000			1000(800)		1000(600)		1000(800)					
Remark																	

Draw-out type 380V 50HZ system

No. for Primary Circuit		08						09									
		A	B	C	D	E	F	A	B	C	D	E	F	G	H	I	
NGC8 LV switchgear																	
Usage		Feeder						Feeder									
Rated current (A)		1600	1250	1000	800	630	500	500	315	250	200	160	100	80	63	32	
Main circuit electrical appliance	Disconnector	EX9A	2000	1600	1250	1000	800	630	630	400	315	250	200	160	125	100	63
		NA8	2000	1600	1250	1000	800	630	630	400	315	250	200	160	125	100	63
		NA1	2000	1600	1250	1000	800	630	630	400	315	250	200	160	125	100	63
Current induction machine	BH-0.66-□ /5	3	3	3	3	3	3	3	3	3	3	3	3	3	3	1	
Unit high modular ratio		3(9)						3	2	2	2	2	1	1	1	1/2	
Cabinet width(mm)		800	800					1000(600)									
Cabinet depth(mm)		1000(800, 600)						600(1000)									
Remark																	

Draw-out type 380VC 50HZ system

No. for Primary Circuit		10													
		A	B	C	D	E	F	G	H	I	J	K	L	M	
NGC8 LV switchgear															
		Usage		Across the line starting											
Rated power (KW)		250	200	160	110	90	75	37	30	22	15	11	7.5	5.5	
Main circuit electrical appliance	Disconnecter	Ex9M	630	500	400	250	225	200	125	100	80	63	25	20	16
		NM8	630	500	400	250	225	200	125	100	80	63	32	20	16
		NM1	630	500	400	250	225	200	125	100	80	63	25	20	16
	Contactor	LC1/A/Ex9C	550	550	370	260	210	175	90	75	63	40	30	25	16
	Thermal relay	LRD/TA/Ex9R	5A	5A	5A	5A	5A	5A	5A	63A	45A	30A	22A	15A	11A
	Current induction machine	BH-0.66-12 /5	3	3	3	3	3	3	3	1	1	1			
Unit high modular ratio		4	4	3	3	3	2	2	1	1	1	1/2	1/2	1/2	
Cabinet width(mm)		1000(600)													
Cabinet depth(mm)		600(1000)													
Remark															

Draw-out type 380VC 50HZ system

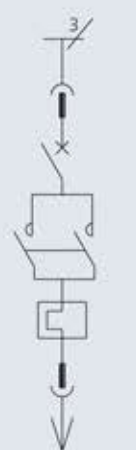
No. for Primary Circuit		11													
		A	B	C	D	E	F	G	H	I	J	K	L	M	
NGC8 LV switchgear															
Usage		Ordered start													
Rated power (KW)		250	200	160	90	75	55	37	30	22	15	11	7.5	5.5	
Main circuit electrical appliance	Disconnector	Ex9M	630	500	400	225	200	160	125	100	80	63	25	20	16
		NM8	630	500	400	225	200	160	125	100	80	63	32	20	16
		NA1	630	500	400	225	200	160	125	100	80	63	25	20	16
	Contactor	LC1/A/Ex9C	550	550	370	210	175	145	90	75	63	40	30	25	16
	Thermal relay	LRD/TA/Ex9R	5A	5A	5A	5A	5A	5A	5A	63A	45A	30A	22A	15A	11A
	Current induction machine	BH-0.66-□ /5	3	3	3	3	3	3	3						
Unit high modular ratio		4	4	3	3	2	2	2	1	1	1/2	1/2	1/2	1/2	
Cabinet width(mm)		1000(600)													
Cabinet depth(mm)		600(1000)													
Remark															

Draw-out type 380VC 50HZ system

No. for Primary Circuit		12												
		A	B	C	D	E	F	G	H	I	J	K	L	
NGC8 LV switchgear														
Usage		star-delta starting												
Rated power (KW)		200	160	110	90	75	55	45	37	30	22	18.5	11	
Main circuit electrical appliance	Disconnector	Ex9M	500	400	250	225	200	160	125	125	100	80	63	25
		NM8	500	400	250	225	200	160	125	125	100	80	63	32
		NM1	500	400	250	225	200	160	125	125	100	80	63	25
	Contactor	LC1/A/Ex9C	5A	5A	5A	5A	5A	5A	5A	46	44	44	42	40
	Thermal relay	LRD/TA/Ex9R	5A	5A	5A	5A	5A	5A	5A	5A	36A	25A	21A	13A
	Current induction machine	BH-0.66-□ /5	3	3	3	3	3	3	3	3				
Unit high modular ratio		4	4	3	3	3	2	2	2	1	1	1	1	
Cabinet width(mm)		1000(600)												
Cabinet depth(mm)		600(1000)												
Remark														

Plugin type 380VC 50HZ system

No. for Primary Circuit		13													
		A	B	C	D	E	F	G	H	I	J	K	L	M	
NGC8 LV switchgear															
Usage		across the line starting													
Rated power (KW)		250	200	160	110	90	75	37	30	22	15	11	7.5	5.5	
Main circuit electrical appliance	Disconnector	Ex9M	630	500	400	250	225	200	125	100	80	63	32	20	16
		NM8	630	500	400	250	225	200	125	100	80	63	32	20	16
		NM1	630	500	400	250	225	200	125	100	80	63	25	20	16
	Contactor	LC1/A/Ex9C	550	550	370	260	210	175	90	75	63	40	30	25	16
Thermal relay	LRD/TA/Ex9R	5A	5A	5A	5A	5A	5A	5A	63A	45A	30A	22A	15A	11A	
Current induction machine	BH-0.66-□ /5	3	3	3	3	3	3	3	1	1	1				
Unit high modular ratio		4	4	3	3	3	2	2	1	1	1	1/2	1/2	1/2	
Cabinet width(mm)		1000(600)													
Cabinet depth(mm)		600(1000)													
Remark															

Plugin type 380VC 50HZ system

No. for Primary Circuit		14													
		A	B	C	D	E	F	G	H	I	J	K	L	M	
NGC8 LV switchgear															
Usage		Ordered start													
Rated power (KW)		250	200	160	90	75	55	37	30	22	15	11	7.5	5.5	
Main circuit electrical appliance	Disconnector	Ex9M	630	500	400	225	200	160	125	100	80	63	32	20	16
		NM8	630	500	400	225	200	160	125	100	80	63	32	20	16
		NM1	630	500	400	225	200	160	125	100	80	63	25	20	16
	Contactor	LC1/A/Ex9C	550	550	370	210	175	145	90	75	63	40	30	25	16
	Thermal relay	LRD/TA/Ex9R	5A	5A	5A	5A	5A	5A	5A	63A	45A	30A	22A	15A	11A
	Current induction machine	BH-0.66-□ /5	3	3	3	3	3	3	3						
Unit high modular ratio		4	4	3	3	2	2	2	1	1	1/2	1/2	1/2	1/2	
Cabinet width(mm)		1000(600)													
Cabinet depth(mm)		600(1000)													
Remark															

Modular internal separation structure of 380VC 50HZ system

No. for Primary Circuit		15														
		A	B	C	D	E	F	G	H	I	J	K	L	M		
NGC8 LV switchgear																
Usage		Across the line starting														
Rated power (KW)		250	200	160	110	90	75	37	30	22	15	11	7.5	5.5		
Main circuit electrical appliance	Disconnector	Ex9M	630	500	400	250	225	200	125	100	80	63	32	20	16	
		NM8	630	500	400	250	225	200	125	100	80	63	32	20	16	
		NM1	630	500	400	250	225	200	125	100	80	63	25	20	16	
	Contactor	LC1/A/Ex9C	550	550	370	260	210	175	90	75	63	40	30	25	16	
	Thermal relay	LRD/TA/Ex9R	5A	5A	5A	5A	5A	5A	5A	63A	45A	30A	22A	15A	11A	
	Current induction machine	BH-0.66- /5	3	3	3	3	3	3	3	1	1	1				
Unit high modular ratio		4	4	3	3	3	2	2	1	1	1	1/2	1/2	1/2		
Cabinet width(mm)		1000(600)														
Cabinet depth(mm)		600(1000)														
Remark																

Modular internal separation structure of 380VC 50HZ system

No. for Primary Circuit		16														
		A	B	C	D	E	F	G	H	I	J	K	L	M		
NGC8 LV switchgear																
Usage		Ordered start														
Rated power (KW)		250	200	160	90	75	55	37	30	22	15	11	7.5	5.5		
Main circuit electrical appliance	Disconnector	Ex9M	630	500	400	225	200	160	125	100	80	63	32	20	16	
		NM8	630	500	400	225	200	160	125	100	80	63	32	20	16	
		NM1	630	500	400	225	200	160	125	100	80	63	25	20	16	
Contactor	LC1/A/Ex9C	550	550	370	210	175	145	90	75	63	40	30	25	16		
Thermal relay	LRD/TA/Ex9R	5A	5A	5A	5A	5A	5A	5A	63A	45A	30A	22A	15A	11A		
Current induction machine	BH-0.66-□ /5	3	3	3	3	3	3	3								
Unit high modular ratio		4	4	3	3	2	2	2	1	1	1/2	1/2	1/2	1/2		
Cabinet width(mm)		1000(600)														
Cabinet depth(mm)		600(1000)														
Remark																

Modular internal separation structure of 380V 50HZ system

No. for Primary Circuit		17												
		A	B	C	D	E	F	G	H	I	J	K	L	
NGC8 LV switchgear														
Usage		Star-delta starting												
Rated power (KW)		200	160	110	90	75	55	45	37	30	22	18.5	11	
Main circuit electrical appliance	Disconnector	Ex9M	500	400	250	225	200	160	125	125	100	80	63	32
		NM8	500	400	250	225	200	160	125	125	100	80	63	32
		NM1	500	400	250	225	200	160	125	125	100	80	63	25
	Contactor	LC1/A/Ex9C	54	52	50	50	48	47	46	46	44	44	42	40
	Thermal relay	LRD/TA/Ex9R	5A	5A	5A	5A	5A	5A	5A	5A	36A	25A	21A	13A
	Current induction machine	BH-0.66-□ /5	3	3	3	3	3	3	3	3				
Unit high modular ratio		4	4	3	3	3	2	2	2	1	1	1	1	
Cabinet width(mm)		1000(600)												
Cabinet depth(mm)		600(1000)												
Remark														

Reactive compensation of 380VC 50HZ system

No. for Primary Circuit		13									14						
		A	B	C	D	E	F	G	H	I	A	B	C	D	E	F	
NGC8 LV switchgear																	
Usage		Reactive compensation									Reactive compensation						
step number (n)		12			10			8			10			8			
Each step/total capacity (Kvar)		25/300	20/240	15/180	30/300	20/200	15/150	30/240	20/160	15/120	30/300	20/200	15/150	30/240	20/160	15/120	
Main circuit electrical appliance	Disconnecter Fuse	HH15	630	630	630	630	630	630	630	630	630						
		NH000										125	125	125	125	125	125
	Fuse	5SF	63	63	63	63	63	63	63	63	63						
		NT□	630	500	400	630	400	315	500	400	315	63	40	32	63	40	32
	Contactor	C16C/C19/C39/C49	63	40	32	63	40	32	63	40	32	63	40	32	63	40	32
	Capacitor	BSMJ0.4-□	25	20	15	30	20	15	30	20	15	63	40	32	63	40	32
	Arrester	Y3W1															
	Controller	JKL-□	12	12	12	10	10	10	8	8	8	10	10	10	8	8	8
Current induction machine	BH-0.66-□ /5	3	3	3	3	3	3	3	3	3	3	3	3	3	3	3	
Unit high modular ratio		9									9						
Cabinet width(mm)		1000(800、600)									1000(800、600)						
Cabinet depth(mm)		1000(800、600)									1000(800、600)						

12. Internal partition form

In order to protect personal safety and property, IEC 61439-2 standard defines that the switch cabinet is divided into several independent compartments in different ways, which are called parted form by using baffles and separator to separate them.

- Form 1: No partition.
- Form 2: Divide bus from functional unit, and separate the external terminals from the bus.
- Form 3: Bus and functional units and all functional units are separated respectively. Divide the external terminals and functional units, without dividing them respectively. Divide external terminals and the bus.
- Form 4: Bus and functional units and all functional units are separated respectively, including the external connection terminal composed of functional units.

Diagram:

 Bus rod, including distribution bus

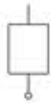

functional unit, including external connecting spot of guide line

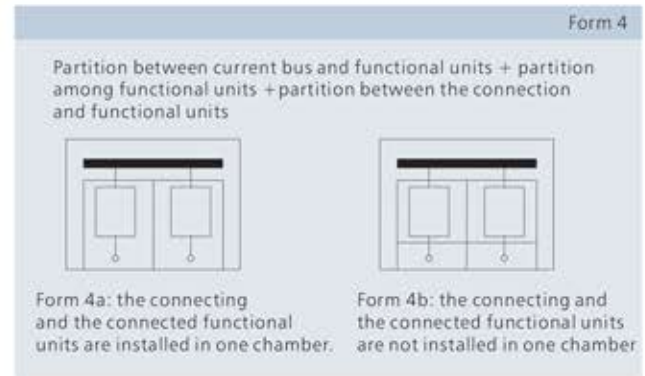
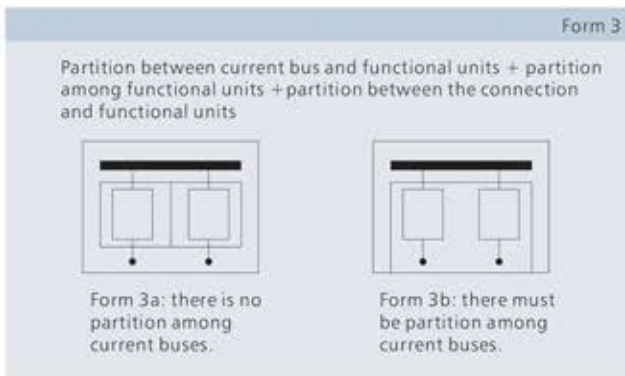
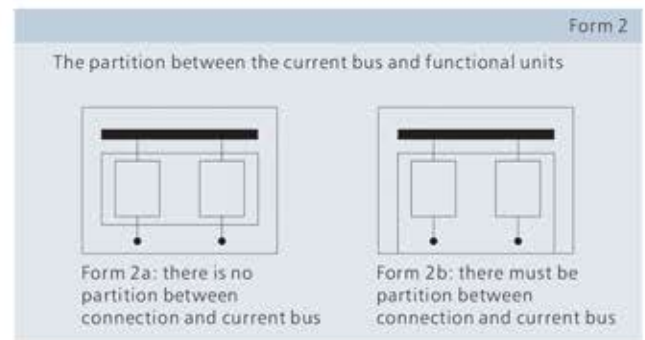
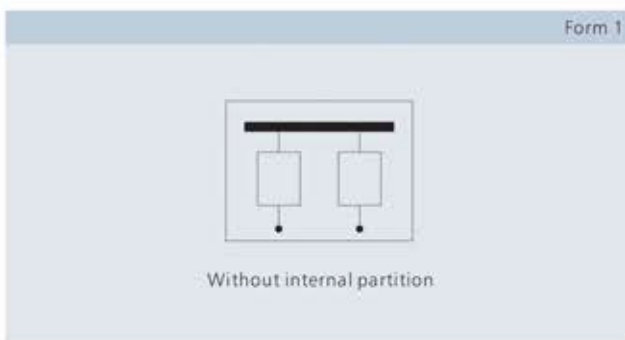



13. Degree of protection

External influences: national and international standards have different categories of influence on external electrical equipment protection, such as external solids and water from entering.







Degree of protection: IEC6052B clearly defines the IP code, which can be a number of degree of protection provided by the case.

- Prevent external solid foreign objects from entering(the first number)
- Prevent water from entering(the second number)

Prevent external solid foreign objects from entering

0		No protection
1		Prevent solid foreign matter with diameter more than 50mm
2		Prevent solid foreign matter with diameter more than 12mm
3		Prevent solid foreign matter with diameter more than 2.5mm
4		Prevent solid foreign matter with diameter more than 1mm
5		Prevent dust(no harmful participation)
6		Complete dust prevention

Prevent water from entering

0		No protection
1		Prevent vertical dripping
2		Prevent dripping from 15 degrees vertical direction
3		Prevent dripping from 60 degrees vertical direction
4		Prevent spraying from all directions
5		Prevent intense spraying from all directions
6		Prevent soaking
7		Prevent continuous soaking

14. Installation and transportation

- There must be the specific distance between switch cabinet and barrier

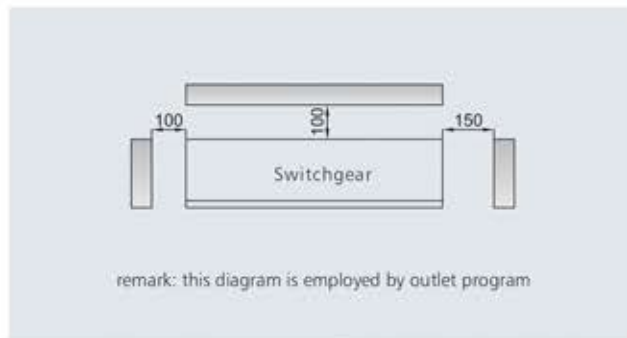

- Operating maintenance channel

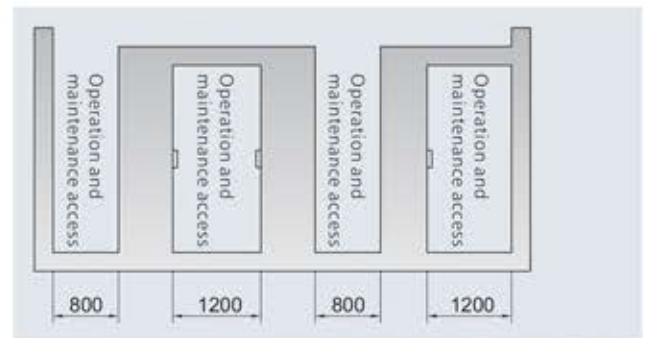

- Derating factor when altitude is above 2000m

Altitude (m)	Coefficient
to 2200	0.88
to 2400	0.87
to 2500	0.86
to 2700	0.85
to 2900	0.84
to 3000	0.83
to 3300	0.82
to 3500	0.81
to 4000	0.78
to 4500	0.76
to 5000	0.74

- The top of the switch cabinet should leave at least 400mm space from the barrier surface
- If the front of switch cabinet is opposite, so only the side that is shortened by the opening of the door should be taken into consideration, and the door can not be closed from the exit side.
- Request the door to be open at least 90 degrees.
- The transportation unit can be one cabinet or many cabinets, but there should always be the unified pedestal.

15. Floor installation size

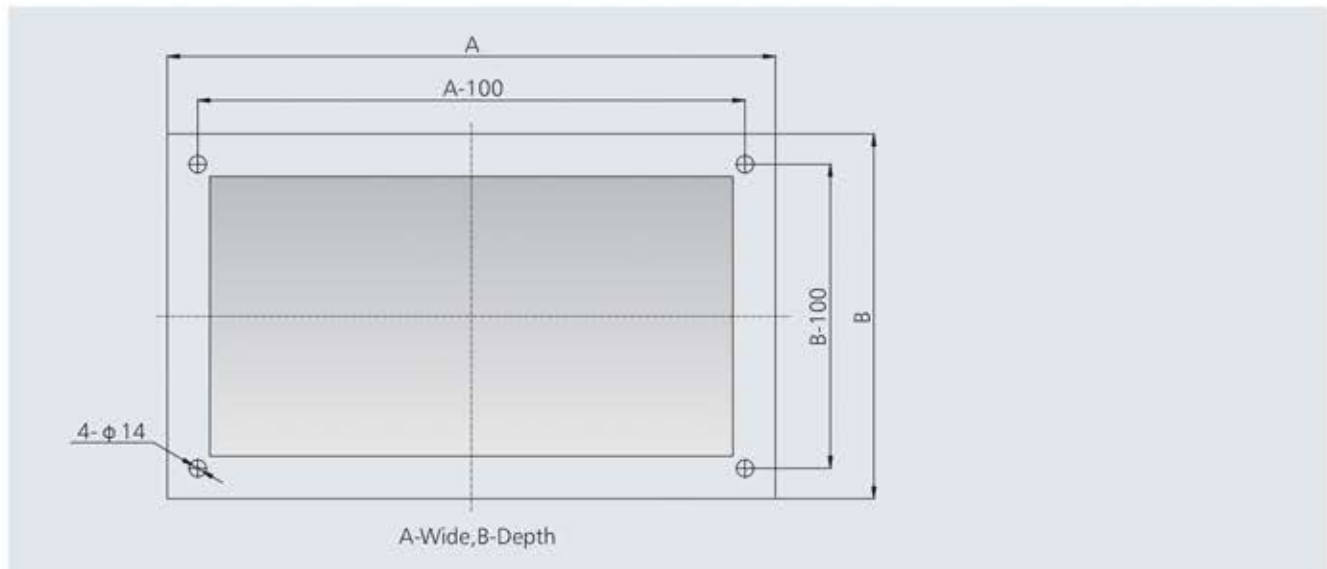

Note: The above-stated data is only for reference, and our company reserves the right to modify it.

16. Ordering information

- Installation method of cabinet shape
- Main circuit
- Auxiliary circuit electrical schematic diagram
- Component model and parameters of electrical equipment with specific requirements
- The name, quantity and other requirements of spare parts.
- The unmatched specific requirements of the products under normal conditions and miscellaneous.

CHINT GLOBAL PRESENCE

China Based, World Visioned

- 3 Global Research Centers: Europe, North America, Asia Pacific
- 6 International Marketing & Sales Areas: Asia Pacific, Middle East and Africa, Europe, Latin America, North America, China
- 9 Manufacturing Bases: China (Wenzhou, Shanghai, Hangzhou, Xianyang, Jiuquan), Egypt, Germany, Thailand
- 14 International Subsidiaries
- 17 Marketing Offices in China
- 22 Logistics Centers
- 2300 Sales Companies



CHINT | EGEMAC

CHINT EGEMAC for electrical products Co.Ltd.

Address: Industrial Park, 6th of October - Egypt
Tel: (+2) 3864 2389 - (+2) 3864 2368
Mob: (+2) 012 2801 8443
E-mail: Haytham.kandil@chint-egemac.com
E-mail: Chenbh@chint.com
Website: www.chint.net



2018

